

Before assembly

- We recommend that time is taken to read the instructions before starting assembly, then follow the easy step by step guide. The instruction sheet is only a guide to the assembly. Certain items may not be shown to scale.
- Check all components prior to assembly
- This product should be assembled by no less than two people.
- Never attempt to erect the assembly in high winds.
- Drill components where indicated.



Recommended tools for assembly

- Drill
- 10mm diameter drill bit
- Hammer
- 10mm spanner
- Spirit level
- Step ladder
- Alan key (provided)



Caution

When connecting components that use the spring button. Please ensure the button is properly located in the hole.

No.	Components	Qty.
1	Left track section with wall bracket	1
2	Right track section with wall bracket	1
3	Runner	10
4	Track section	2
5	Centre track section	1
6	Centre track and upper leg	1
7	Left upper leg	1
8	Right upper leg	1
9	Front connecting bar	2
10	Rear connecting bar	2
11	Lower leg	3
12	Curl finial	3
13	Ball finial	3
14	Foot plate	3
15	Brace (1675mm)	4
16	Brace (1605mm)	4
17	Canopy tubes (1590mm)	2
18	Canopy tubes with push button	10
19	Polyester canopy	1
20	Polyester canopy cover	1

No.	Fixing Kit	Qty.
21	60mm bolts with nuts	3
22	35mm bolt	12
23	10mm bolt	32
24	16mm screws	4
25	Plastic spacer	3
26	Wall fixings	12
27	Foot pegs	6
28	Plastic caps	47

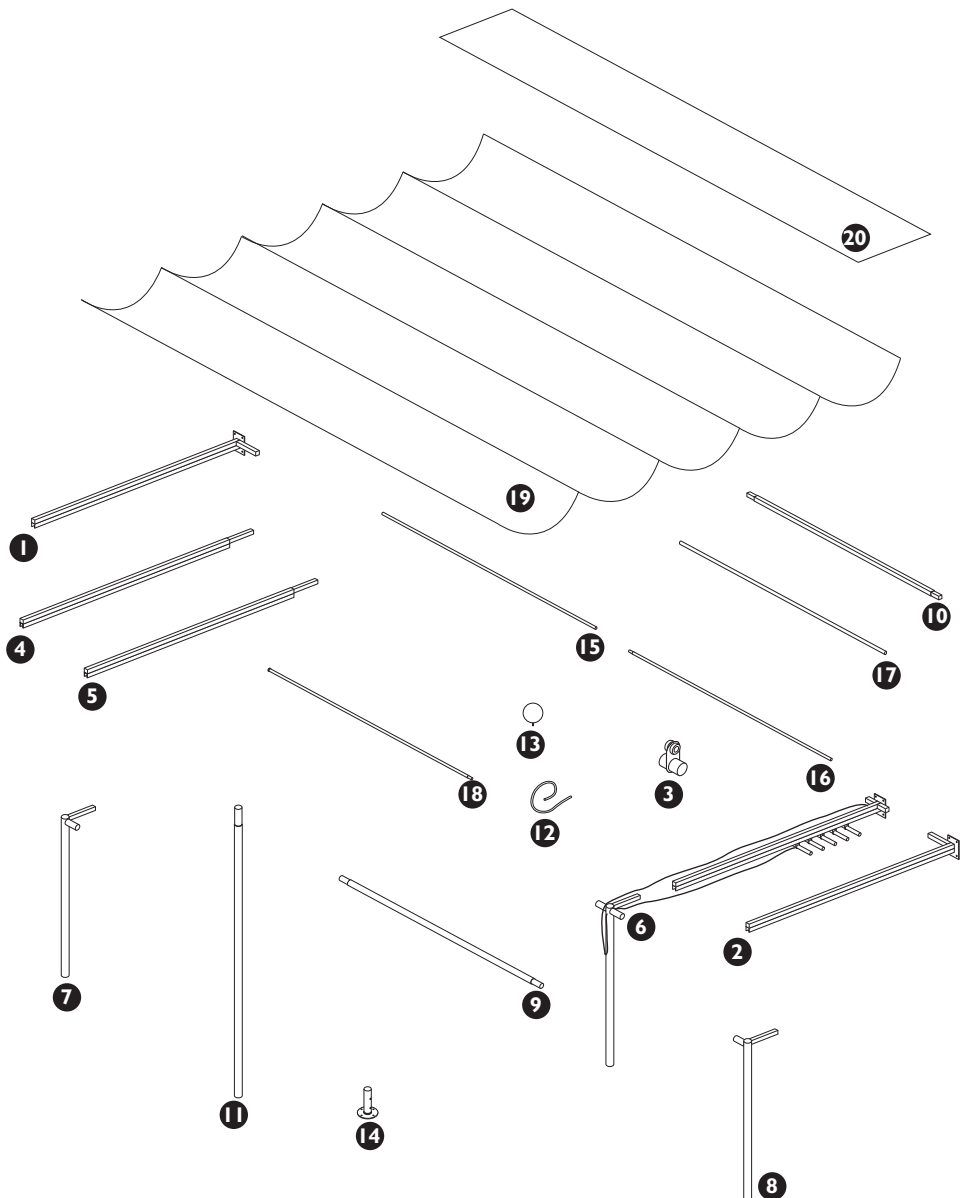
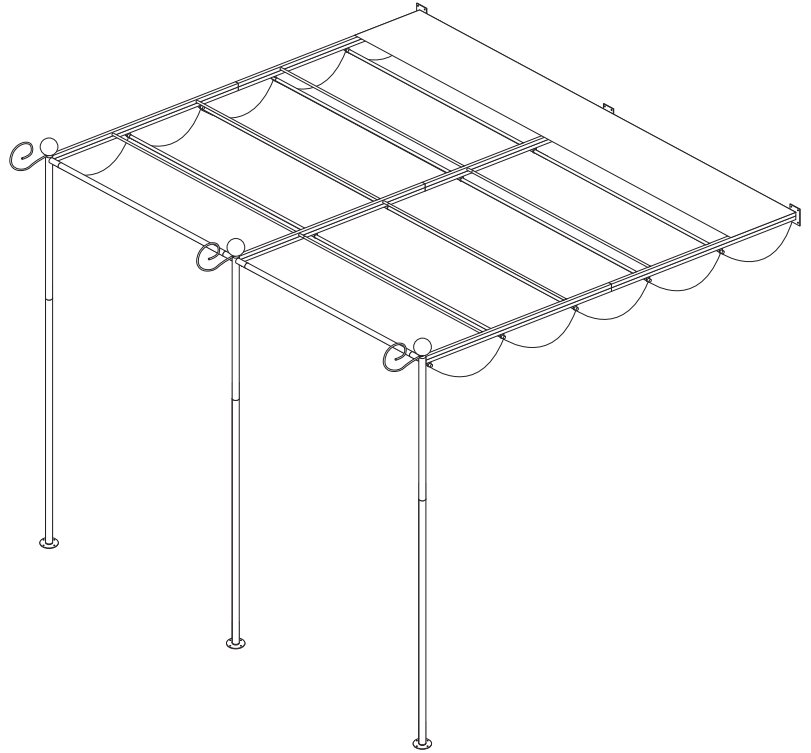

1. Outer Tracks

Insert five runners into each of the two outer tracks sections with wall bracket.

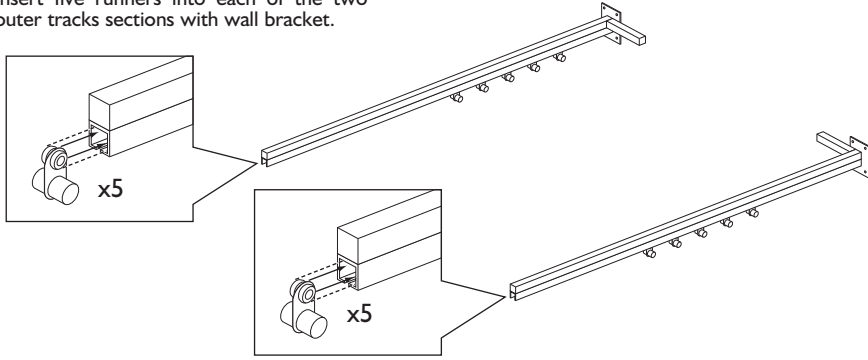

Connect the track sections to the track sections with wall bracket by inserting the coupling into the upper tube of the track with wall brackets. Secure in place using 6 x 10mm bolts for each join.

Attache the upper legs in the same way using 2 x 10mm bolts, ensure correct orientation shown in diagram.

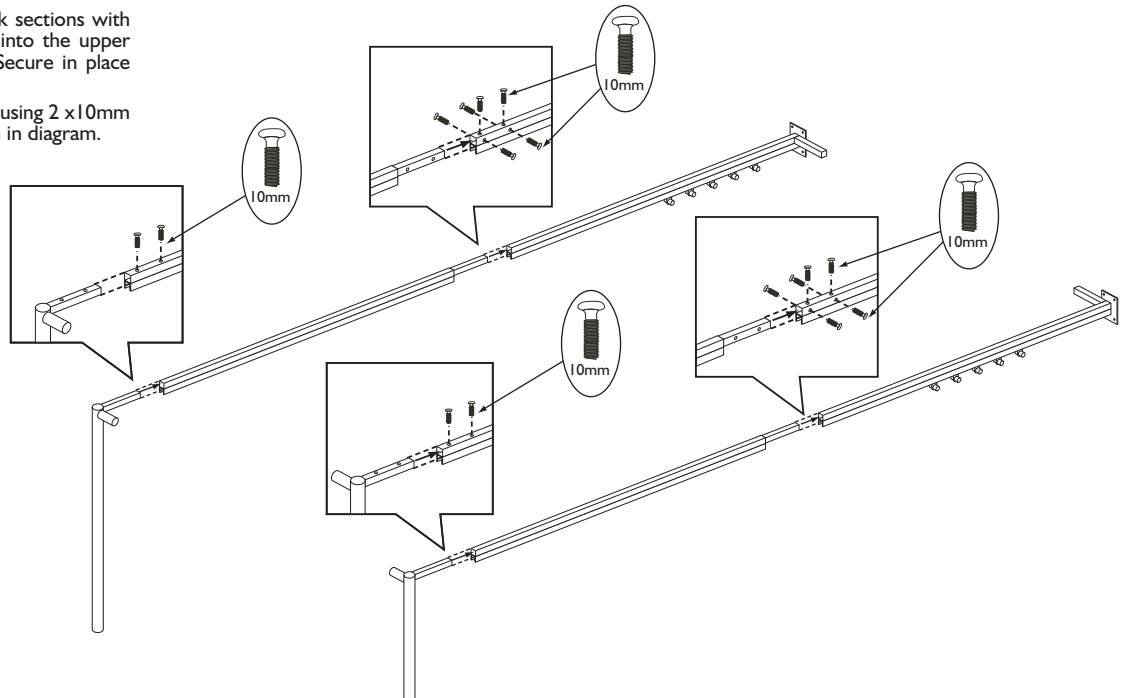

2. Centre track

Assemble the centre track and upper leg section in the same way as the outer tracks. Make sure the pulley rope is not trapped in any of the joins and is able to operate freely.

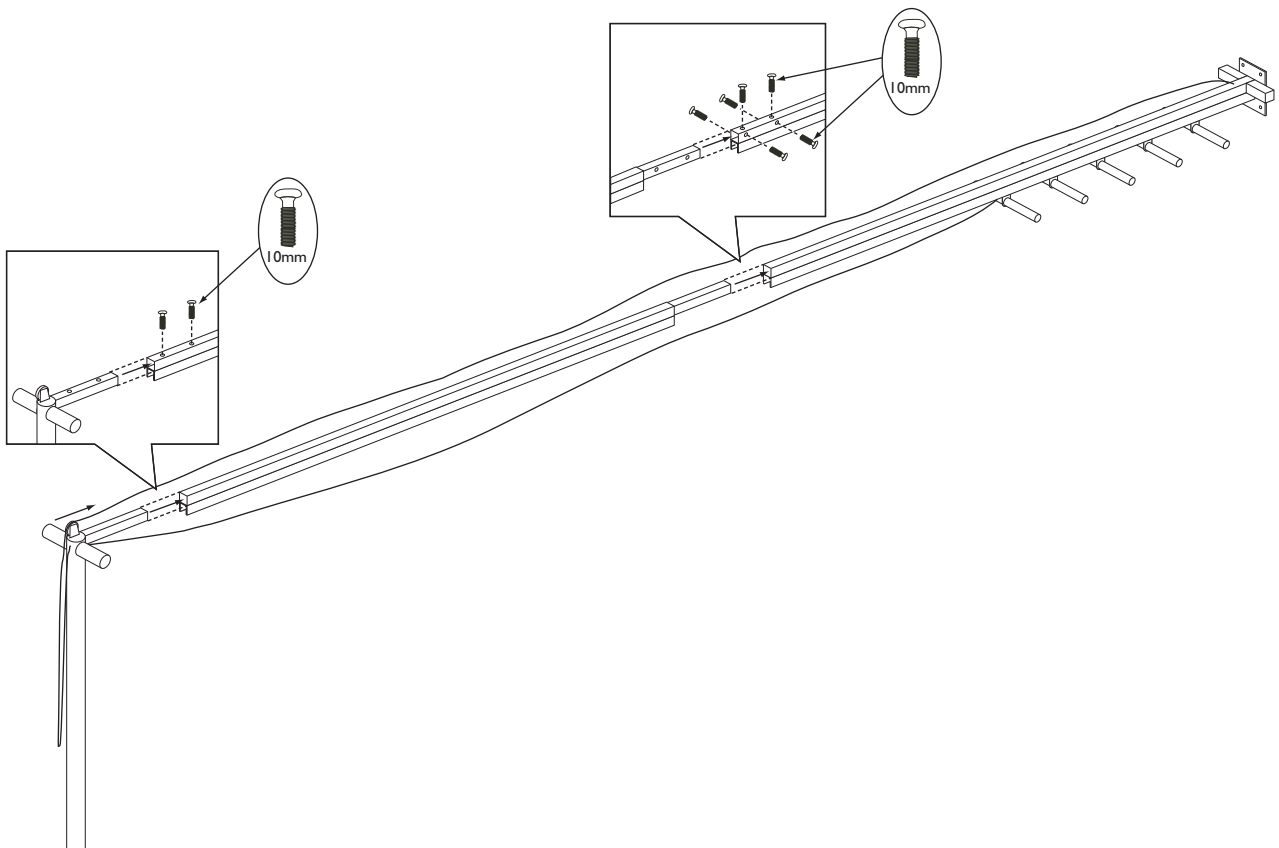

3. Front and rear connecting bars

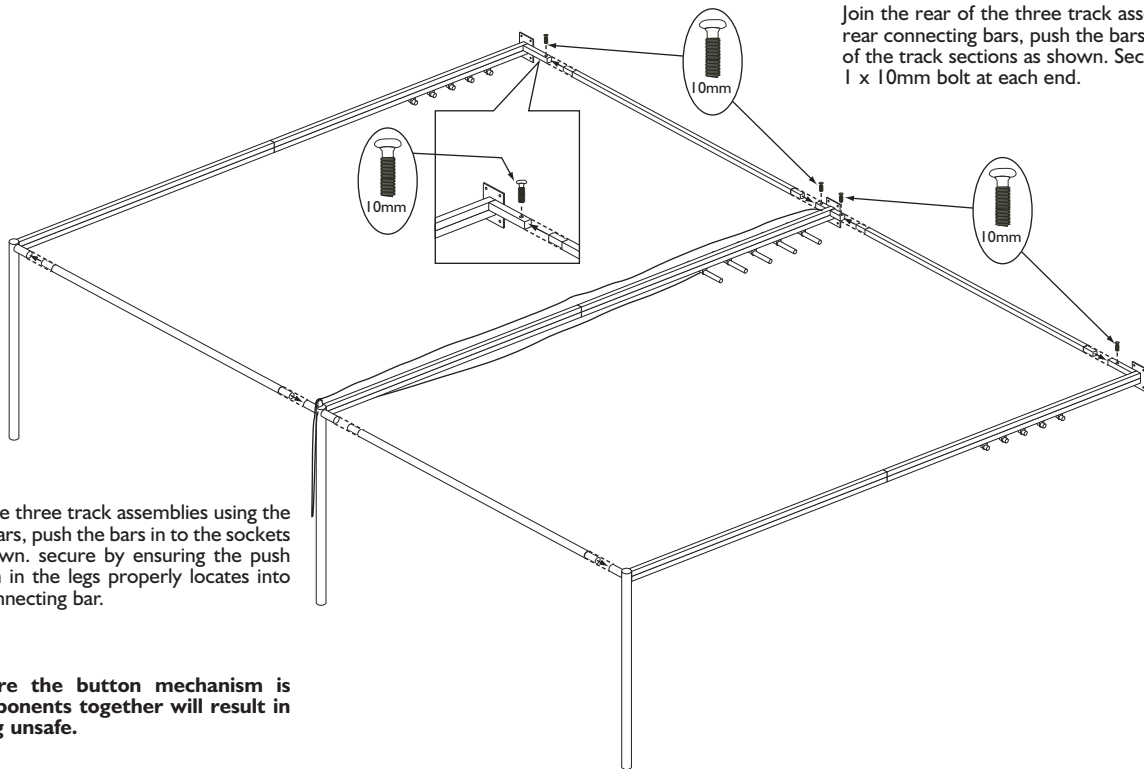

Join the rear of the three track assemblies using the rear connecting bars, push the bars in to the sockets of the track sections as shown. Secure in place using 1 x 10mm bolt at each end.

Join the front of the three track assemblies using the front connecting bars, push the bars in to the sockets of the legs as shown. secure by ensuring the push button mechanism in the legs properly locates into the hole of the connecting bar.

Please note:

Failure to ensure the button mechanism is locking the components together will result in the canopy being unsafe.

4. Lower legs and finials

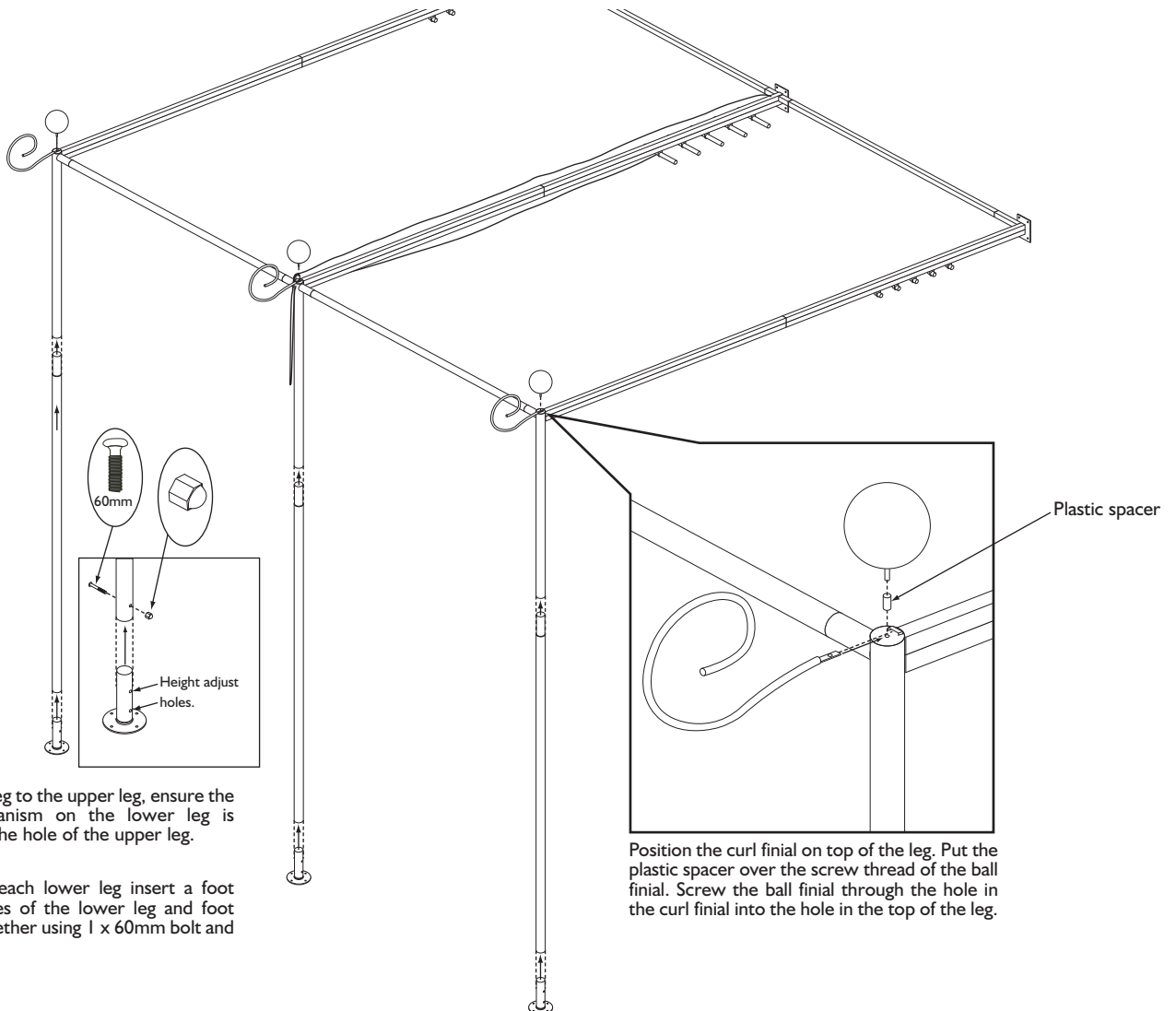

Connect the lower leg to the upper leg, ensure the push button mechanism on the lower leg is properly located in the hole of the upper leg.

On the bottom of each lower leg insert a foot plate. Align the holes of the lower leg and foot plate and secure together using 1 x 60mm bolt and nut per foot.

Please note:

The two holes in the post of the foot plate are to adjust the height of the canopy. Ensure the same height hole is use on all three legs.

Position the curl finial on top of the leg. Put the plastic spacer over the screw thread of the ball finial. Screw the ball finial through the hole in the curl finial into the hole in the top of the leg.

5. Connecting frame to the wall

When erecting the canopy frame, judgement should be used to determine the most appropriate fixing component to attach the metal plates to the exterior wall, bearing in mind the strength and condition of the wall. If deemed inappropriate, substitute the included wall fixing.

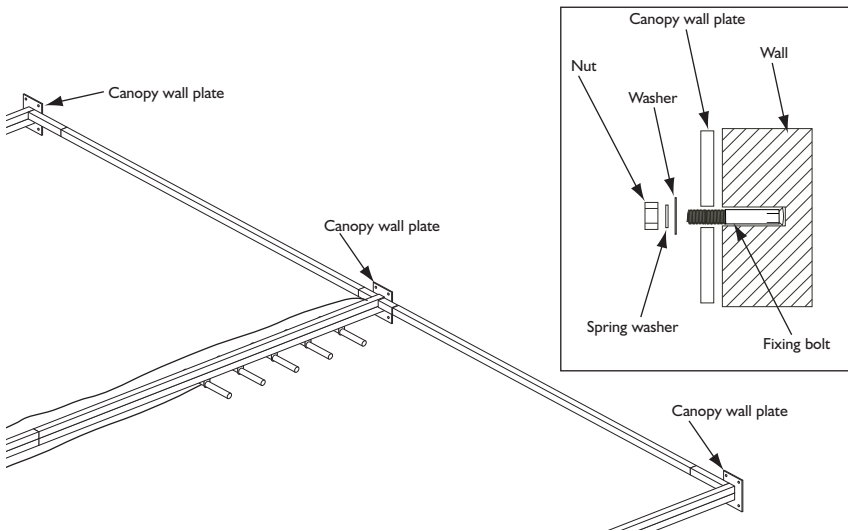

Put the canopy frame into position, ensure the feet are flat on the floor and the tracks are level using a spirit level. Mark the wall with the position of the 4 holes of each wall plate.

For included fixings:

Remove the frame work and drill 10mm diameter holes at positions marked to a depth of 50mm.

Gently tap the fixing bolts into the hole.

Reposition the canopy frame on to the studs and secure using the washer, spring washer and the nut.

6. Frame bracing

Insert a 1675mm brace through each of the holes in the centre track and connect it to a 1605mm brace as shown. Fit the outer ends of the braces between the outer tracks and secure using 1 x 35mm bolt at each end. Push the bolts through the track frame and screw into the ends of the braces. With all braces in position screw down through the holes in the top of the centre track into each brace using 1 x 16mm screws for each brace.

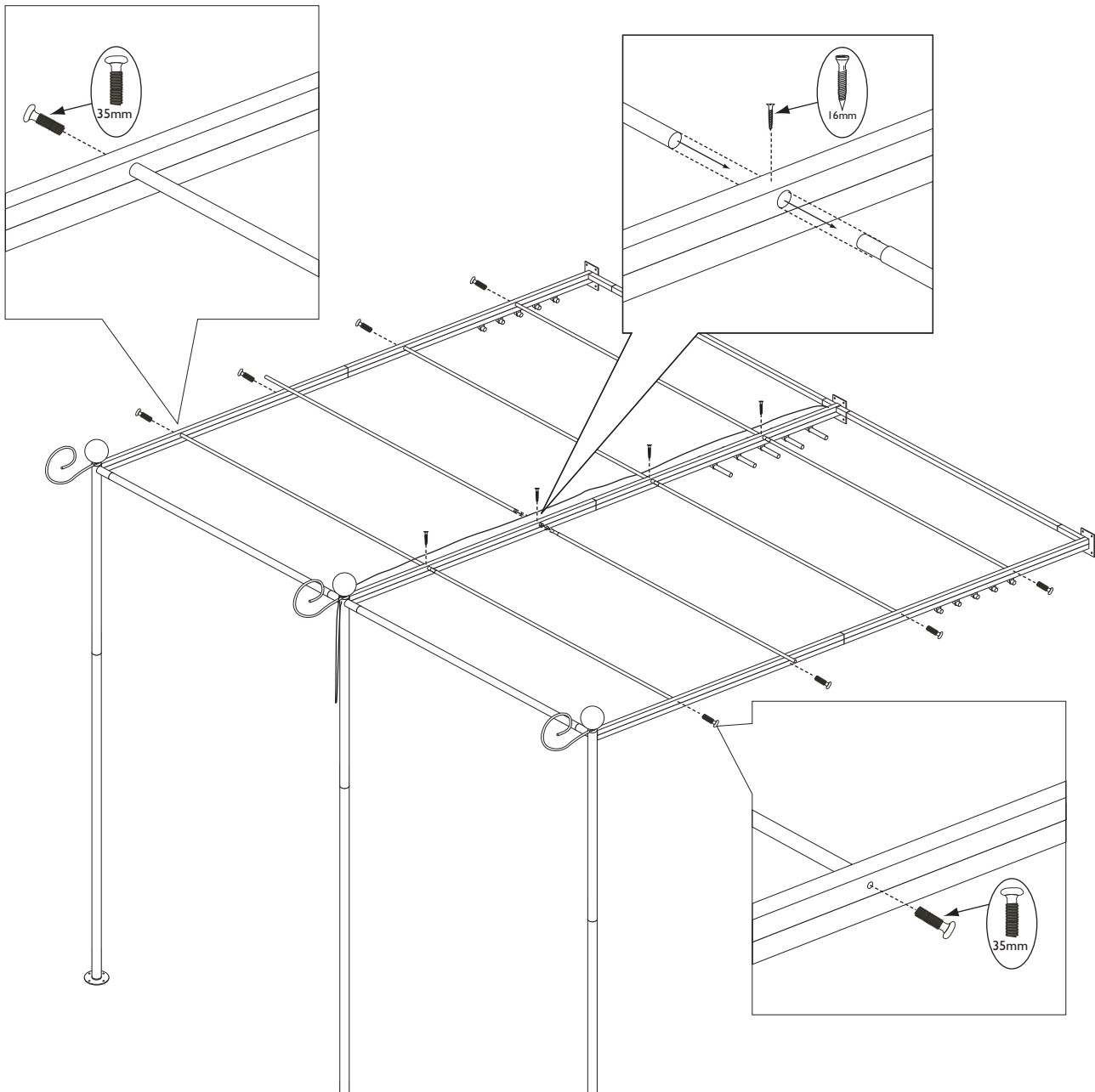

7. Attaching the wall end of the polyester canopy

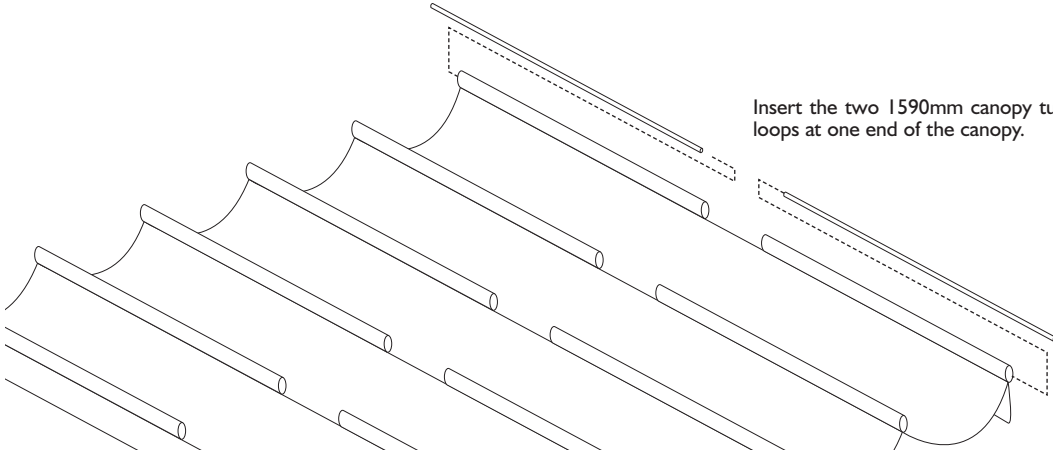

Insert the two 1590mm canopy tubes into the two loops at one end of the canopy.

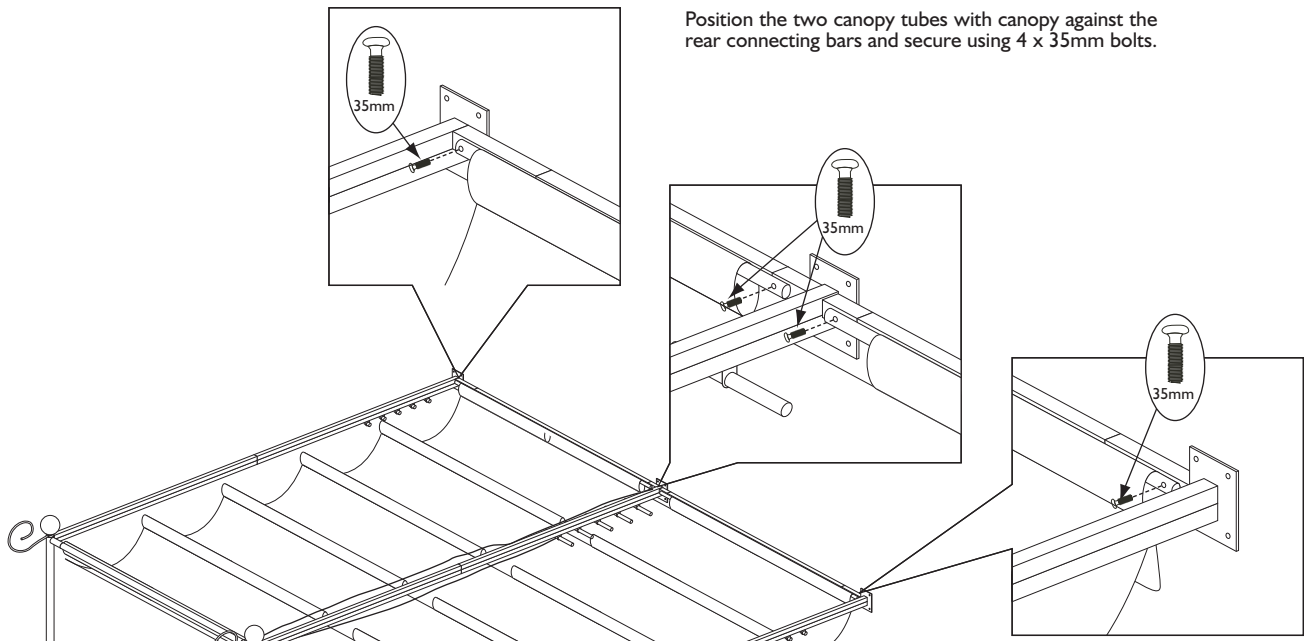

Position the two canopy tubes with canopy against the rear connecting bars and secure using 4 x 35mm bolts.

8. Attaching polyester canopy to the runners

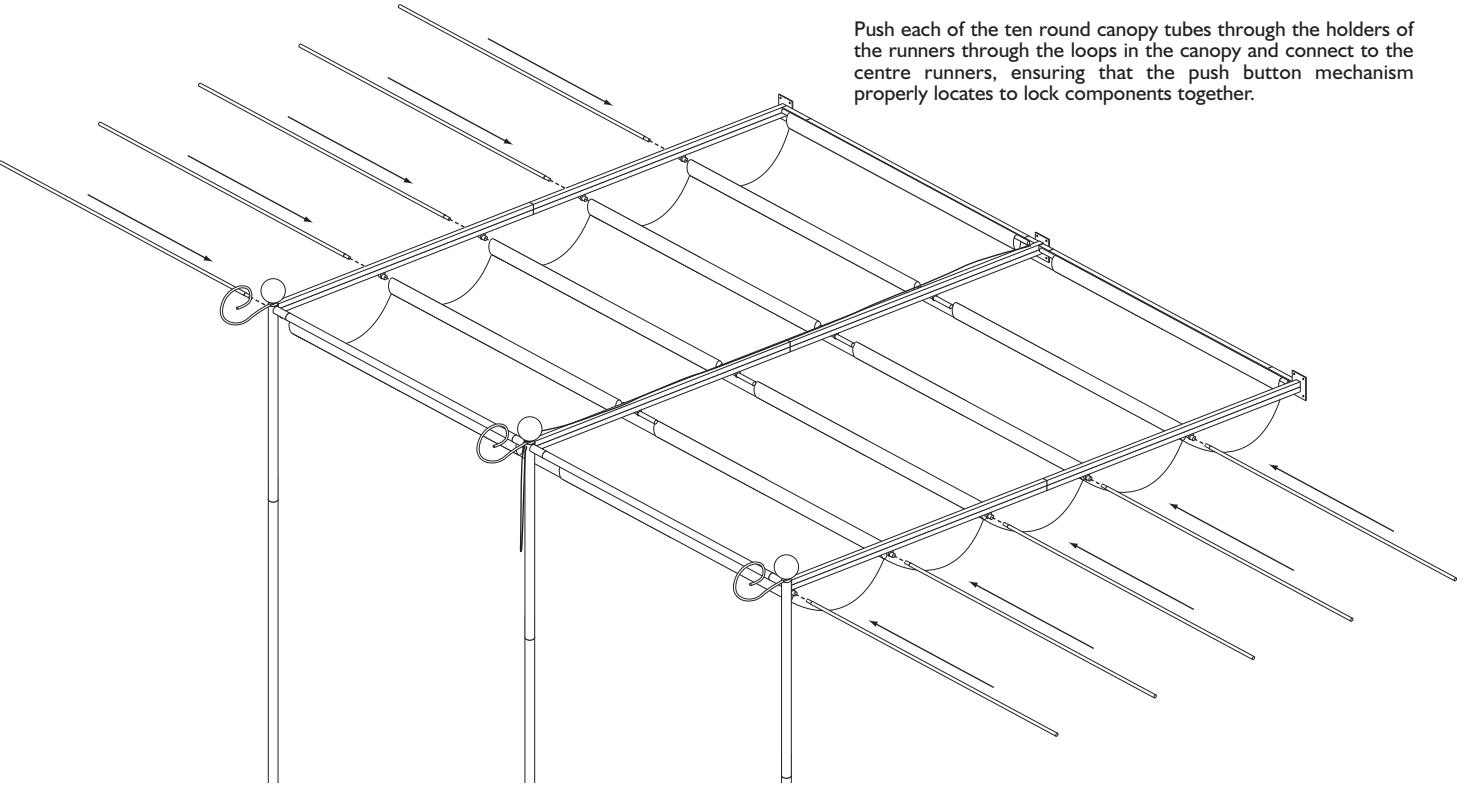

Push each of the ten round canopy tubes through the holders of the runners through the loops in the canopy and connect to the centre runners, ensuring that the push button mechanism properly locates to lock components together.

9. Attaching polyester canopy cover

Position the polyester canopy cover on top of the metal frame at the wall end. Secure to the top of the frame using 4 x 10mm bolts as shown below.

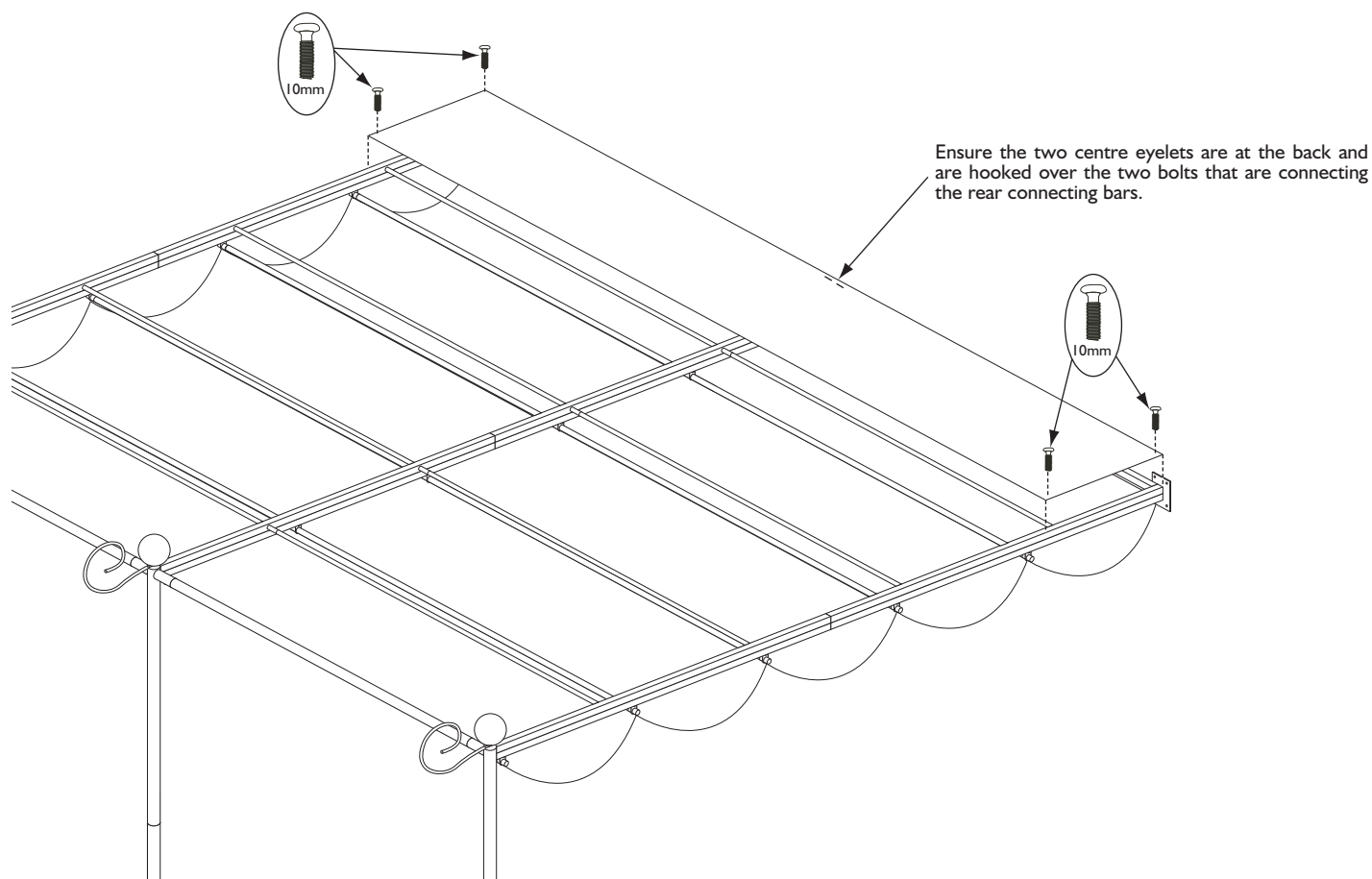

Important information

- Please ensure that the canopy is erected on a stable, level and sturdy surface.
- Ideally, the canopy should be fixed to a level concrete patio base using appropriate fixings. If the canopy is to stand on grass, it is important that the canopy is level in order to ensure a smooth retracting mechanism, and the canopy should be secured into place using fixing pegs (supplied).
- When erecting the canopy frame, judgement should be used to determine the most appropriate fixing component to attach the metal plates to the exterior wall, bearing in mind the strength and condition of the wall. If deemed inappropriate, substitute the included wall fixing.
- Please note that the St. Tropez Canopy is not designed to be used as a rain shelter, despite the polyester canopy being shower proof.
- We recommend that the polyester canopy be fully retracted when not in use.
- The polyester canopy should be fully removed in anticipation of strong winds and during the winter period.
- The polyester canopy must be completely dry before storage.
- Eyelets in the canvas are drain holes to prevent water collecting and stretching the canvas.

Maintenance

- To clean the polyester canopy, sponge clean using a mild soap and water solution and leave to dry naturally. Do not use bleach, acid or other solvents.
- Do not machine wash.
- Do not tumble dry.

Safety

In order to gain the most from your new canopy, attention should be paid to the following safety precautions:

1. Periodically check bolts and fittings for tightness as they may work loose over time, taking care not to over-tighten fittings as this may damage the metalwork. For this reason, we do not recommend the use of power tools to assemble the canopy frame.
2. Please note that the metal frame is not to be used as a climbing frame.

FIRE PRECAUTIONS

- PLEASE NOTE THAT THE CANOPY IS NOT FIRE RETARDANT AND CAN BURN
- DO NOT USE NAKED FLAMES IN THE VICINITY OF THE CANOPY
- BARBECUES AND/OR PATIO HEATERS SHOULD NOT BE USED EITHER UNDERNEATH OR IN THE VICINITY OF THE CANOPY

If in doubt of any aspect regarding the assembly, use or safety of your canopy please contact us :

Help Line (Normal Office Hours) 01829 261 121

ROWLINSON GARDEN PRODUCTS LIMITED
Green Lane
Wardle Nr.Nantwich
Cheshire
CW5 6BN

We constantly improve the quality of our products, occasionally the components may differ from the components shown and are only correct at time of printing. We reserve the right to change the specification of our products without prior notice.

2011 © Rowlinson Garden Products Ltd